

- True deep cycle AGM technology-GREEN SOLUTION
- Over 99.99% virgin lead for grid plate and active material
- Heavy duty grid/paste design for deep cycle application
- Maintenance free, non-spillable, valve-regulated
- Double separator configuration: long cycle life & high energy density and super anti-vibration design
- Low self-discharge for longer shelf life



ELECTRICAL SPECIFICATIONS

Voltage (V)	Capacity (AH)					Reserve Capacity (Min)		
	100HR	20HR	10HR	5HR	3HR	@25A	@56A	@75A
12	262	250	225	205	185	540	/	150

PHYSICAL SPECIFICATIONS

Model	Dimensions (mm/inches)				Weight (kg/lbs)	Terminal Type (Standard)	Case Material
	Length	Width	Height	Total Height			
PC12-250-8D	527 (20.75)	280 (11.02)	230 (9.06)	252 (9.92)	72 (158.8)	DT-3/8	PP

OPERATING TEMPERATURE RANGE

Discharge	Charge	Storage
-15°C ~ 50°C (5°F ~ 122°F)	0°C ~ 40°C (32°F ~ 104°F)	-15°C ~ 40°C (5°F ~ 104°F)

APPLICATIONS

- | | | |
|-----------------------------------|-----------------|-----------------|
| Energy Storage / Renewable Energy | Boats and Ships | Solar & Wind |
| Recreational Vehicles | Generators | Golf Carts |
| Fork Lift Trucks | Motive Power | Traffic Signals |
| Uninterruptable Power Supplies | | |

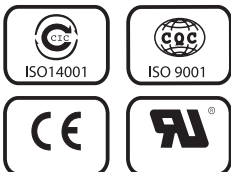

Deep Cycle SLA Battery

■ Dimensions

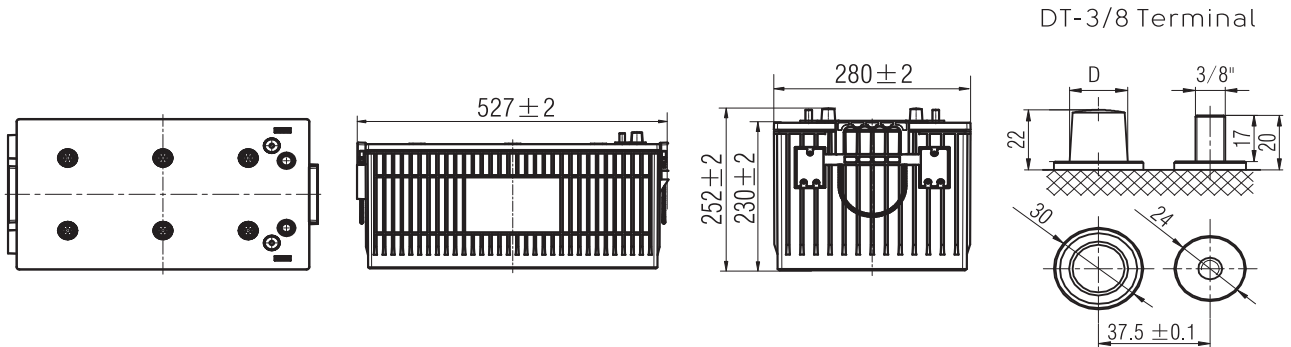

Note: D:Positive $19.5_{-0.3}^0$, D:Negative $17.9_{-0.3}^0$; Terminal Torque Values in-Ib(Nm) : 176-203(20-23)

■ Charging Profile

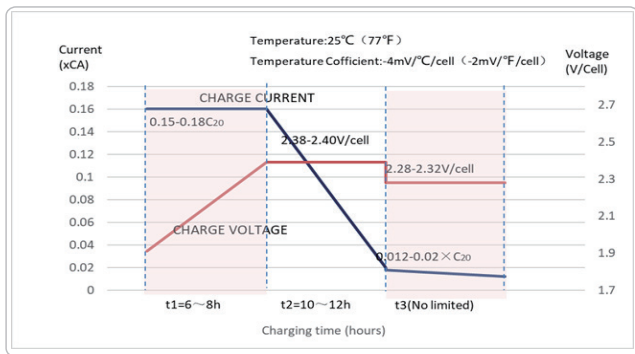

■ Relationship of OCV & State of Charge (25°C, 77°F)

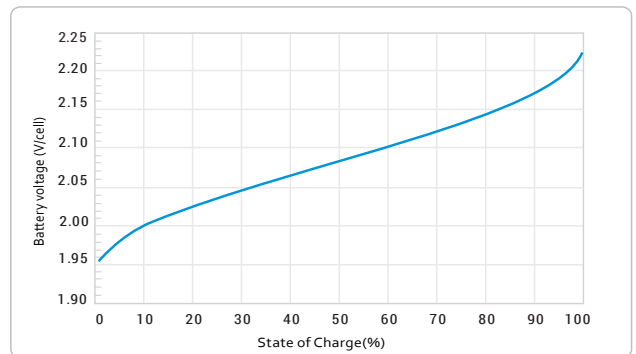

■ Cycle Life in Relation to Depth of Discharge

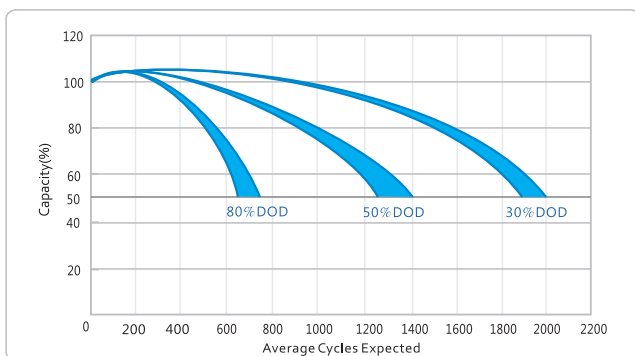

■ Self-Discharge Characteristic

