

**Lithium-ion Battery Cell  
Specification**

**Model: PCL-18650CK**

ZEUS CONFIDENTIAL

**Amendment History**

Rev	Description	Date	Name
Pre	Initial Release	10/22/18	K.O

**Customer Approval**

Company/Customer Name	Department	Date	Signature

**Rechargeable Li-ion Battery**

- **For Air Shipments:** A 30% state of charge (SOC) limit on secondary lithium-ion cells and batteries, including Section II cells and batteries, will now apply. This does not apply to batteries packed with or contained in equipment (Effective April 1, 2016).
- Lithium cells/battery packs must be charged within 45 days of receipt to avoid over discharge.
- Shipping lithium materials must be done through a licensed shipper with appropriate packaging & labeling to meet current regulations.

These amendments are detailed in a lithium battery update document found on the International Air Transport Association (IATA) website: <http://www.iata.org/whatwedo/cargo/dgr/Documents/lithium-battery-update.pdf>

191 Covington Drive, Bloomingdale, IL 60108  
Phone: 630-295-6800 Fax: 630-295-6801  
Toll Free: 877-469-4255

### 1. Scope

This product specification applies to rechargeable Lithium-ion battery cell supplied by Zeus Battery Products.

### 2. Description and Model

Model: PCLI-N18650CK

Description: 3.6V 3000mAh

### 3. Nominal Specifications

No.	Item	Specification	Remark
1	Nominal Capacity	3000mAh	@ 0.5C discharge, room temperature
2	Nominal Voltage	3.7V	
3	Charge Voltage	4.20V	
4	Max. charge current	3A	Not for cycle life
5	Max. discharge current	8.7A	Not for cycle life
6	Discharge cut-off Voltage	2.5V	
7	Internal resistance	≤35mΩ	
8	Weight	Approx. 47g	@ 1Khz AC fully charged
9	Operating temperature	Charge: 0 ~ 45°C Discharge: -20 ~ 60°C	
10	Storage temperature	1 yr: -10 ~ 25°C 6 months: 25 ~ 45°C 1 month: 45 ~ 55°C	Recommended 25+/-5°C at 50% SOC
11	Cycle Life	≥500 cycles	@ 0.5C discharge, room temperature

**\*Note on Air transport: Lithium ion cells and batteries must be offered for transport at a state of charge (SoC) not exceeding 30% of their rated design capacity**

#### 4. Dimension

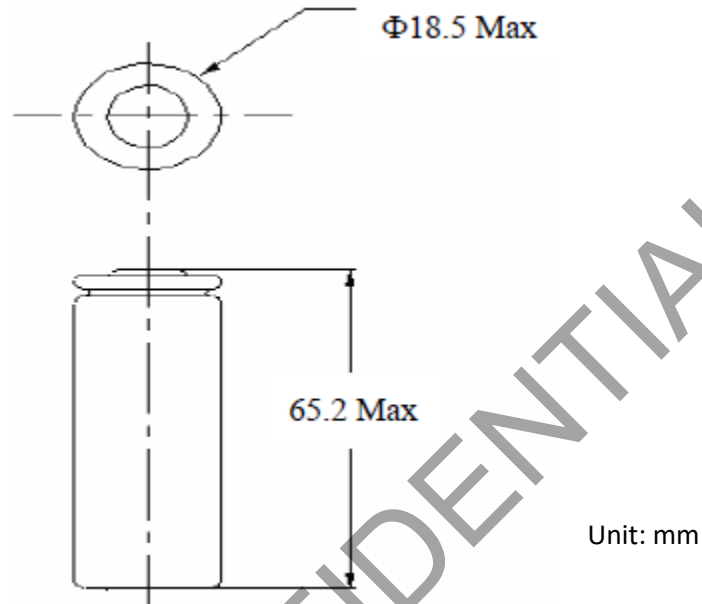

#### 5. Standard Test Conditions

##### 5.1 Environmental Conditions

Unless otherwise specified, all tests stated in this specification are conducted at  $25 \pm 5^\circ\text{C}$  and  $60 \pm 20\%$  humidity.

##### 5.2 Measuring Equipment

###### 1) Ammeter and Voltmeter

Standard class specified in the national standard or more sensitive class

###### 2) Slide caliper

The slide caliper should have 0.01mm accuracy.

###### 3) Impedance meter

An impedance meter with 1kHz AC should be used.

#### 6. Environmental Tests

No	Items	Test Method and Condition	Criteria
1	Overcharge test	Charge the battery using 1C rate until the battery voltage reaches 1.5 times the standard cut off voltage. Observe the battery for 60min afterwards.	No Fire, No explosion

191 Covington Drive, Bloomingdale, IL 60108

Phone: 630-295-6800 Fax: 630-295-6801

Toll Free: 877-469-4255

2	130°C oven test	Place a fully charged battery into a temperature chamber. Increase the temperature 5°C/minute until the temperature has reached 130°C. Maintain this temperature for 30 minutes.	No fire, No explosion
3	Crush test	Place a fully charged battery onto a 75mm long half cylinder crush test fixture. The direction of the crushing force shall be vertical to axis of the cylinder. Terminate testing when the battery voltage reaches 0V or the deformation reach 30% or the crushing force reaches 200kN. Observe the battery for 1hour.	No explosion, No fire
4	Short circuit	A fully charged battery is to be induced i to a short-circuit condition by connecting the positive and negative terminals with a copper wires for 10min. The wire resistance shall be less than 5mΩ.	No fire, No explosion
5	Over discharge test	Place 1C load current for 90 minutes and observe for 1 hour.	No fire, no explosion, No leakage

### 7. Battery Handling Warning and Precautions

The battery contains flammable materials such as organic solvents. Mishandling the battery may cause fire, smoke, or an explosion and the battery's functionality will be seriously damaged. Protection

191 Covington Drive, Bloomingdale, IL 60108  
Phone: 630-295-6800 Fax: 630-295-6801  
Toll Free: 877-469-4255

---

circuitry must be designed into the application device to protect the battery. Please read and check the following prohibited actions

**(1) Immersion**

Do not immerse the battery in liquid such as water, beverages, or other fluids. Exposure to liquid may damage the battery or the battery pack (including protection circuit). As a result, the battery may generate heat, smoke, catch fire, or explode.

**(2) High Temperature**

Do not use or place the battery near an open flame, heater or high temperature (above 80°C). Subjecting the battery to high temperature may damage the separator and can cause an internal short circuit. This may cause the battery to generate heat, smoke, catch fire, or explode.

**(3) Chargers and Charge Conditions**

Do not use unauthorized chargers. Only charge the battery within specified conditions (e.g., temperature range, voltage, and current). Use of an unauthorized charger could cause the battery to generate heat, smoke, catch fire, or explode.

**(4) Reverse Polarity**

Do not attach or insert battery with polarity reversed. A battery has polarity. If the battery does not easily fit into the charger or device, check the battery's orientation. Do not force the battery into the battery compartment. If attached to the device with reversed polarity, the battery may generate heat, smoke, catch fire, or explode.

**(5) Direct Connection**

Do not connect the battery to an AC outlet or DC automotive plug. The battery requires a specific charger. If the battery is connected directly to a power outlet, the battery may generate heat, smoke, catch fire, or explode.

**(6) Use in Other Equipment**

Do not use the battery in equipment for which it was not intended. If the battery is used in unapproved applications or systems, the battery may become damaged and generate heat, smoke, catch fire, or explode.

**(7) Incineration and Heat**

Keep the battery away from heat and fire. Heat will damage the battery and may cause it to generate heat, smoke, catch fire, or explode.

**(8) Short-Circuit**

Do not apply short-circuit. Do not connect the positive (+) and negative (-) terminals with a conductive material. Do not carry or store the battery with any metal objects. If the battery is shorted, the shorting item may overheat and the battery may generate heat, smoke, catch fire, or explode.

**(9) Impact**

Avoid excessive impact to the battery. Impact beyond specification may damage the battery. This may cause the battery to leak, generate heat, smoke, catch fire, or explode.

**(10) Penetration**

---

191 Covington Drive, Bloomingdale, IL 60108  
Phone: 630-295-6800 Fax: 630-295-6801  
Toll Free: 877-469-4255

Do not penetrate the battery with a nail or strike with a hammer.

If subjected to a hard strike or penetrated by an object, the battery may be damaged or destroyed, thereby causing an internal short-circuit. This may cause the battery to generate heat, smoke, catch fire, or explode.

**(11) Soldering**

Do not directly solder to the battery.

Soldering directly to the battery could melt the separator or damage the gas release vent or other safety mechanisms. This may cause the battery to generate heat, smoke, catch fire, or explode.

**(12) Disassembly**

Do not disassemble the battery.

Disassembly or modification of the battery may damage the protection circuit. This may cause the battery to generate heat, smoke, catch fire, or explode.

**(13) Charge near High Temperatures**

Do not charge the battery near high temperature.

If the battery is charged while exposed to high temperature, the battery's protection circuit may activate and prevent charging, or fail and cause the battery to generate heat, smoke, catch fire, or explode.

**(14) Deformation**

Do not use the battery with conspicuous damage or deformation.

It causes the generating heat, smoke, rupture or flame.

**(15) Reverse Charge and Overdischarge**

Do not reverse polarity (and terminals).

On charging, the battery is reverse-charged and abnormal chemical reaction occurs. And also, there may be case that unexpected large current flows on discharging, and can generate heat, smoke, rupture or flame.

**Additional Precaution**

- ◆ The battery should be stored at half charged state in a dry, clean area with good ventilation. If the battery has to be stored for extended period of time (over 3 months), the environmental condition should be 20+/-5°C with 65+/-20% Relative Humidity.
- ◆ Charging current and voltage should be less than maximum charge current specified in the Product Specification. Charging with higher current or voltage than recommended value may damage the battery and lead to poor performance increased safety risk.
- ◆ Do not reverse the polarity of battery pack leads. Reverse charging may cause damage to the battery and lead to degradation of performance and increased safety risk.
- ◆ Parents must explain how to use the system and the battery. Periodic checks must be made to ensure children are using the system and the battery correctly.
- ◆ Always adhere to operating temperature as listed in the Product Specification. Using batteries outside of its operating temperature will lead to reduced performance and increased safety risk.
- ◆ Never short-circuit the battery pack.

191 Covington Drive, Bloomingdale, IL 60108

Phone: 630-295-6800 Fax: 630-295-6801

Toll Free: 877-469-4255

---

- 
- ◆ If electrolytes leak and come into contact with the skin or eyes, flush with fresh water and seek medical attention immediately.
  - ◆ Batteries might be damaged during shipping. If abnormal features are present such as damage in a plastic envelop, visible deformation of packaging, or electrolyte odor, the battery shall not be used and placed in a safe well ventilated area away from heat source.
  - ◆ Batteries must be partially recharged if stored for more than 6 months.
  - ◆ Do not store batteries at fully charged state as it could lead to swelling, leakage or loss of performance and or shelf life. For long term storage 50% SOC is recommended.

### 8. Warranty

Products supplied by Zeus Battery Products contain 12 months warranty against manufacturing defects from date of manufacture. Zeus Battery Products shall not be responsible for any accident or damage resulting either from user abuse or misuse.

*Note: This product specification is subject to change without prior notice.*

ZEUS CONFIDENTIAL